

THE LEX-PLUS-POWER INEQUALITY FOR LOCAL COHOMOLOGY MODULES

GIULIO CAVIGLIA AND ENRICO SBARRA

ABSTRACT. We prove an inequality between Hilbert functions of local cohomology modules supported in the homogeneous maximal ideal of standard graded algebras over a field, within the framework of embeddings of posets of Hilbert functions. As a main application, we prove an analogue for local cohomology of Evans' Lex-Plus-Power Conjecture for Betti numbers. This result implies some cases of the classical Lex-Plus-Power Conjecture, namely an inequality between extremal Betti numbers. In particular, for the classes of ideals for which the Eisenbud-Green-Harris Conjecture is currently known, the projective dimension and the Castelnuovo-Mumford regularity of a graded ideal do not decrease by passing to the corresponding Lex-Plus-Power ideal.

INTRODUCTION

The Eisenbud-Green-Harris (**EGH**) and Evans' Lex-Plus-Power (**LPP**) conjectures are two open problems in Algebraic Geometry and Commutative Algebra which are challenging and of great interest to researchers in these fields, cf. [EiGrHa1], [EiGrHa2], [MePeSt], [MeMu], [FrRi], [Pe], [CaMa], [Ch], [Fr], [Ri], [RiSa]. The survey [PeSt], which includes the two conjectures above, might offer the interested reader an overview of questions which are currently considered to be significant for the classification of Hilbert functions and the study of modules of syzygies. A milestone on this subject is yielded by the work of Macaulay, cf. [Ma] or the dedicated sections in [BrHe], where the sequences of numbers which are possible Hilbert functions of standard graded algebras over a field are characterized, the characterization having been made possible by the introduction of a special class of monomial ideals called lexicographic ideals (lex-segment ideals for short). More precisely, all the possible Hilbert functions of standard graded algebras over a field are attained by quotients of polynomial rings by lex-segment ideals. In the 60's, some forty years after Macaulay's work, Kruskal-Katona Theorem [Kr], [Ka] provided another fundamental classification result, that of f -vectors of simplicial complexes, and shortly after it was generalized by the Clements-Lindström Theorem [CLi]. Both Kruskal-Katona and Clements-Lindström Theorems extend Macaulay Theorem from graded quotients of $A = K[X_1, \dots, X_n]$ to graded quotients of $R = A/\mathfrak{a}$, where $\mathfrak{a} = (X_1^{d_1}, \dots, X_r^{d_r})$ with $d_1 = \dots = d_r = 2$ and $2 \leq d_1 \leq \dots \leq d_r$ resp., by stating that all the possible Hilbert functions are those attained by quotients whose defining ideals are images in R of lex-segment ideals of A . Inspired by these results and driven

Date: March 11, 2013.

2010 Mathematics Subject Classification. Primary 13D02, 13D45; Secondary 14B15.

Key words and phrases. Eisenbud-Green-Harris Conjecture, Lex-Plus-Power Conjecture, embeddings of Hilbert functions, local cohomology.

The work of the first author was supported by a grant from the Simons Foundation (209661 to G. C.).

by the of generalizing the famous Cayley-Bacharach Theorem, Eisenbud, Green and Harris [EiGrHa1], [EiGrHa2] conjectured among other things what is currently known as **EGH**: Let $\mathbf{f} = f_1, \dots, f_r$ be a regular sequence of homogeneous polynomials of degrees $d_1 \leq \dots \leq d_r$ in A . Then, for every homogeneous ideal $I \subset A$ containing \mathbf{f} , there exists a lex-segment ideal L of A such that I and $L + (X_1^{d_1}, \dots, X_r^{d_r})$ have the same Hilbert function. Since then, the conjecture has been proven only in some special cases, cf. [CaMa], [Ch] and [FrRi].

Furthermore, starting in the early 90's, lex-segment ideals - and other monomial ideals with strong combinatorial properties - have been studied extensively; properties of lex-segment ideals have been generalized and studied also in other contexts, see for instance [ArHeHi1], [ArHeHi2], generating a very rich literature on the subject. Among other results of this kind, we recall the following ones. The lex-segment ideal in the family of all homogeneous ideals with a given Hilbert function has largest Hilbert functions of local cohomology modules, which was proved in [Sb]. Also, it has largest graded Betti numbers, as it was shown [Bi], [Hu] and [Pa]. In a different direction these are other extensions of Macaulay's result. Evans' Lex-Plus-Power Conjecture extends in this sense the Eisenbud-Green-Harris Conjecture to Betti numbers, by asking whether, in case **EGH** holds true, a Bigatti-Hulett-Pardue type of result holds as well, i.e. **LPP**: Suppose that a regular sequence \mathbf{f} verifies **EGH**; then the graded Betti numbers over A of every homogeneous ideal I containing \mathbf{f} are smaller than or equal to those of $L + (X_1^{d_1}, \dots, X_r^{d_r})$. The conjecture is known in some few cases, the most notable one is when \mathbf{f} is a monomial regular sequence, which is solved first in [MePeSt] when $d_1 = \dots = d_r = 2$ and then in general in [MeMu].

We now take a step back, and recall that the graded Betti numbers $\beta_{ij}^A(A/I)$ are precisely the dimension as a K -vector space of $\text{Tor}_i^A(A/I, K)_j$. In other words, once we have fixed i , we can think the sequence of $\beta_{ij}^A(A/I)$ as the Hilbert function of $\text{Tor}_i^A(A/I, K)$, which is computed by means of a minimal graded free resolution of A/I . If we let $\text{Hilb}(M)$ denote the Hilbert series of a graded module M , then we may restate **LPP** as coefficient-wise inequalities between the Hilbert series of such Tor's: if \mathbf{f} satisfies **EGH** then for all homogeneous ideals I of A containing \mathbf{f}

$$\text{(LPP)} \quad \text{Hilb} \left(\text{Tor}_i^A(A/I, K) \right) \leq \text{Hilb} \left(\text{Tor}_i^A(A/(L + (X_1^{d_1}, \dots, X_r^{d_r})), K) \right), \quad \text{for all } i.$$

In this paper we study analogous inequalities for Hilbert series of local cohomology modules. Let $H_m^i(\bullet)$ denote the i^{th} local cohomology module of a graded object with support in the graded maximal ideal. One of our main results is Theorem 4.4, where we show that, if the image of \mathbf{f} in a suitable quotient ring of A satisfies **EGH** (as it does in all the known cases [CLi], [CaMa], [Ch] and [Ab]) then for all homogeneous ideals I of A containing \mathbf{f}

$$\text{(Theorem 4.4)} \quad \text{Hilb} \left(H_m^i(A/I) \right) \leq \text{Hilb} \left(H_m^i(A/(L + (X_1^{d_1}, \dots, X_r^{d_r}))) \right), \quad \text{for all } i.$$

Our approach makes use of *embeddings of Hilbert functions*, which have been recently introduced by the first author and Kummini in [CaKu1] with the intent of finding a new path to the classification of Hilbert functions of quotient rings. Since **EGH** may be rephrased by means of embeddings, as we explain in Section 2, it is natural to study inequalities of the above type in this generality. In this setting we prove our main result Theorem 3.1, which implies Theorem 4.4. We let R, S be standard graded K -algebras such that R embeds into (S, ϵ) , see Definition 2.3. We also assume that, for all homogeneous ideals I of

R , $\text{Hilb}\left(H_{\mathfrak{m}_R}^i(R/I)\right) \leq \text{Hilb}\left(H_{\mathfrak{m}_S}^i(S/\epsilon(I))\right)$ for all i . Then, Theorem 3.1 states that the polynomial ring $R[Z]$ embeds into $(S[Z], \epsilon_1)$ and, for all homogeneous ideals J of $S[Z]$ and for all i ,

$$\text{Hilb}\left(H_{\mathfrak{m}_{R[Z]}}^i(R[Z]/J)\right) \leq \text{Hilb}\left(H_{\mathfrak{m}_{S[Z]}}^i(S[Z]/\epsilon_1(J))\right).$$

Finally, in Theorem 5.4 we prove **LPP** for extremal Betti numbers: under the same assumption of Theorem 4.4 for all homogeneous ideals I of A containing \mathfrak{f} and for all corners (i, j) of $A/L + (X_1^{d_1}, \dots, x_r^{d_r})$ we have

$$\text{(Theorem 5.4)} \quad \beta_{ij}^A(A/I) \leq \beta_{ij}^A(A/L + (X_1^{d_1}, \dots, x_r^{d_r})).$$

This paper is structured as follows. In Section 1 we introduce some general notation and we discuss the basic properties of certain ideals called Z -stable, together with all the related technical results needed, such as distractions. In Section 2 we provide a brief summary of embeddings of Hilbert functions and we recall in Theorem 2.2 a General Restriction Theorem type of result proved in [CaKu1]. This is aimed at setting the general framework for our main theorem and leads to the proof of Proposition 2.6, which is the other main tool we need. Section 3 is devoted to our main theorem, Theorem 3.1. We show there that if a ring R admits an embedding of Hilbert functions and its embedded ideals $\epsilon(I)$ maximize all the Hilbert functions of local cohomology modules $H_{\mathfrak{m}}^i(R/\bullet)$, the same is true for any polynomial ring with coefficients in R . In Section 4 we explain how to derive from Theorem 3.1 our main corollary, Theorem 4.4, a lex-plus-power type inequality for local cohomology which justifies the title. Finally, in the last section we prove the validity of **LPP** for extremal Betti numbers in Theorem 5.4 and we show in Theorem 5.5 an inclusion between the region of the Betti table outlined by the extremal Betti numbers of an ideal and the one of its corresponding Lex-Plus-Power ideal.

1. Z -STABILITY

1.1. Notation. Let \mathbb{N} be the set of non-negative integers, $A = K[X_1, \dots, X_n]$ be a polynomial ring over a field K and $R = \bigoplus_{j \in \mathbb{N}} R_j = A/\mathfrak{a}$ be a standard graded algebra. We consider the polynomial ring $R[Z]$ with the standard grading. When I is an ideal of $R[Z]$, we will denote by \bar{I} its image in R under the substitution map $Z \mapsto 0$. With $\text{Hilb}(M)$ we denote the Hilbert series of a module M which is graded with respect to total degree and with $\text{Hilb}(M)_j$ its j^{th} coefficient, i.e. the j^{th} value of its Hilbert function. Accordingly, $\text{Hilb}(M)_{\bullet}$ will denote the Hilbert function of M . We say that an ideal I of $R[Z]$ is Z -graded if it can be written as $\bigoplus_{h \in \mathbb{N}} I_{\langle h \rangle} Z^h$, where each $I_{\langle h \rangle}$ is a homogeneous ideal of R . In particular a Z -graded ideal of $R[Z]$ is homogeneous. We will denote with \mathfrak{m}_R and $\mathfrak{m}_{R[Z]}$ the homogeneous maximal ideals of R and $R[Z]$ respectively.

1.2. Z -stability. The following definition was introduced in [CaKu1].

Definition 1.1. Let $I = \bigoplus_{h \in \mathbb{N}} I_{\langle h \rangle} Z^h$ be a Z -graded ideal of $R[Z]$. We say that I is Z -stable if, for all $k \geq 0$, we have $I_{\langle k+1 \rangle} \mathfrak{m}_R \subseteq I_{\langle k \rangle}$.

The simplest example of a Z -stable ideal is the extension to $R[Z]$ of an ideal J of R , in which case $JR[Z] = \bigoplus_{h \in \mathbb{N}} JZ^h$. It is easy to see that Z -stable ideals are fixed under the action

on $R[Z]$ of those coordinates changes of $K[X_1, \dots, X_n, Z]$ which are both homogeneous and R -linear.

Remark 1.2. (a) Let I be a Z -stable ideal of $R[Z]$ and let us write the degree d component I_d of I as a direct sum of vector spaces $V_d \oplus V_{d-1}Z \oplus \dots \oplus V_0Z^d$. It follows directly from Definition 1.1 that, for all $j = 0, \dots, d$, the j^{th} component of the R -ideal generated by $\bigoplus_{j=0}^d V_j$ is the vector space V_j .

(b) It is immediately seen that the ideal $I : Z = \bigoplus_{h \in \mathbb{N}} I_{\langle h+1 \rangle} Z^h$ is Z -stable as well. Furthermore, we observe that $I : Z = I : \mathfrak{m}_{R[Z]}$; one inclusion is clear and the other follows from

$$\mathfrak{m}_{R[Z]}(I : Z) = \bigoplus_{h \in \mathbb{N}} I_{\langle h+1 \rangle} (\mathfrak{m}_R + Z) Z^h \subseteq \bigoplus_{h \in \mathbb{N}} I_{\langle h \rangle} Z^h + \bigoplus_{h \in \mathbb{N}} I_{\langle h+1 \rangle} Z^{h+1} \subseteq I.$$

In particular, $I^{\text{sat}} := \bigcup_i (I : \mathfrak{m}_{R[Z]}^i) = \bigcup_i (I : Z^i) =: I : Z^\infty$ is a Z -stable ideal.

The next result about Z -stable ideals will be used later in the paper.

Lemma 1.3. *Let I and J be Z -stable ideals of $R[Z]$ with $\text{Hilb}(I)_i = \text{Hilb}(J)_i$ for all $i \gg 0$. Then, $\text{Hilb}(\bar{I})_j = \text{Hilb}(\bar{J})_j$ for all $j \gg 0$.*

Proof. Since $i \gg 0$, we may assume that there is no generator of I or J in degree i and above. As in Remark 1.2 (a), we denote the vector space of all homogeneous polynomials in I of degree i by I_i , and we write it as direct sum of vector spaces $V_i \oplus V_{i-1}Z \oplus \dots \oplus V_0Z^i$. From the definition of Z -stability it follows that $I_i(\mathfrak{m}_{R[Z]}_1) \subseteq V_i(\mathfrak{m}_R)_1 \oplus I_iZ$. Hence, we get a decomposition of the vector space I_{i+1} as direct sum $\bar{I}_i(\mathfrak{m}_R)_1 \oplus I_iZ = \bar{I}_{i+1} \oplus I_iZ$. Similarly, we can write J_{i+1} as $\bar{J}_{i+1} \oplus J_iZ$ and now the conclusion follows easily from the hypothesis. \square

1.3. Distractions. Let I be a Z -graded ideal of $R[Z]$ and let $l = \bar{l} + Z$ be an element of $R[Z]$ with $\bar{l} \in R_1$ (and possibly zero). Given a positive degree d we define the (d, l) -*distraction* of I , and we denote it by $D_{(d,l)}(I)$,

$$D_{(d,l)}(I) := \bigoplus_{0 \leq h < d} I_{\langle h \rangle} Z^h \oplus l \left(\bigoplus_{d \leq h} I_{\langle h \rangle} Z^{h-1} \right).$$

It is not hard to see that $D_{(d,l)}(I)$ is an ideal of $R[Z]$ with the same Hilbert function as I , see [CaKu1] Lemma 3.16 and also [BiCoRo] for more information about general distractions of the polynomial ring A . To our purposes, it is important to notice that $D_{(d,l)}(I)$ can be realized in two steps as a polarization of I followed by a specialization. In order to do so, we first define J to be the ideal of $R[Z, T]$ generated by $\bigoplus_{0 \leq h < d} I_{\langle h \rangle} Z^h \oplus T \left(\bigoplus_{d \leq h} I_{\langle h \rangle} Z^{h-1} \right)$. Notice that the Hilbert function of J is the same as the one of $IR[Z, T]$. This implies that $T - Z$ and $T - l$ are $R[Z, T]/J$ -regular, and thus there exist isomorphisms

$$(1.4) \quad R[Z, T]/(J + (T - Z)) \simeq R[Z]/I, \quad R[Z, T]/(J + (T - l)) \simeq R[Z]/D_{(d,l)}(I).$$

We now define a partial order \prec on all the Z -graded ideals of $R[Z]$ by letting

$$(1.5) \quad J \preceq L \quad \text{iff} \quad \text{Hilb} \left(\bigoplus_{k \leq h} J_{\langle k \rangle} Z^k \right) \leq \text{Hilb} \left(\bigoplus_{k \leq h} L_{\langle k \rangle} Z^k \right) \quad \text{for all } h,$$

where $\bigoplus_{k \leq h} J_{\langle k \rangle} Z^k$ and $\bigoplus_{k \leq h} L_{\langle k \rangle} Z^k$ are considered as graded R -modules with $\deg Z^k = k$. We write $J \prec L$ when $J \preceq L$ and at least one of the above inequalities is strict. Let now I be a Z -graded ideal of $R[Z]$ and consider the partially ordered set \mathcal{I} of all Z -graded ideals of $R[Z] = A/\mathfrak{a}[Z]$ with the same Hilbert function as I . We claim that \mathcal{I} has finite dimension as a poset, i.e. the supremum of all lengths of chains in \mathcal{I} is finite. To this end, we fix a monomial order τ on A and we compute the initial ideal with respect to τ of the pre-image in $A[Z]$ of every ideal in \mathcal{I} . In this way, we have constructed a set \mathcal{J} of monomial ideals in $A[Z]$ all with the same Hilbert function, say H . By Macaulay Theorem, this set is finite, for the degrees of the minimal generators of an ideal in \mathcal{J} are bounded above by the degrees of the minimal generators of the unique lex-segment ideal with Hilbert function H . Since every chain of \mathcal{I} lifts to a chain in \mathcal{J} , our claim is now clear.

Proposition 1.6. *Let I be a Z -graded ideal of $R[Z]$ and let $\omega = (1, \dots, 1, 0)$ be a weight vector. If I is not Z -stable, then there exist a positive integer d and a linear form $l = \bar{l} + Z$ with $\bar{l} \in R_1$ such that $I \prec \text{in}_\omega(D_{(d,l)}(I))$.*

Proof. We write I as $\bigoplus_{h \in \mathbb{N}} I_{\langle h \rangle} Z^h$ and we let $d > 0$ be the least positive integer such that $I_{\langle d \rangle} \mathfrak{m}_R \not\subseteq I_{\langle d-1 \rangle}$. Thus, there exists an indeterminate X_j of A such that $I_{\langle d \rangle} X_j \not\subseteq I_{\langle d-1 \rangle}$; therefore we can define l to be the image in $R[Z]$ of $X_j + Z$ and $D_{(d,l)}$ to be the corresponding (d, l) -distraction. Since $D_{(d,l)}(\bigoplus_{j \leq i} RZ^j) \subseteq \bigoplus_{j \leq i} RZ^j$ for all i , we have $I \preceq \text{in}_\omega(D_{(d,l)}(I)) =: J$. Furthermore, $I_{\langle d-1 \rangle} \subseteq J_{\langle d-1 \rangle}$ and $I_{\langle d \rangle} X_j \subseteq J_{\langle d-1 \rangle}$. Since $I_{\langle d \rangle} X_j \not\subseteq I_{\langle d-1 \rangle}$ we deduce that $I_{\langle d-1 \rangle} \subsetneq J_{\langle d-1 \rangle}$, hence $I \prec J$ as desired. \square

From now on, $H_{\mathfrak{m}}^i(\bullet)$ will denote the i^{th} local cohomology with support in the homogeneous maximal ideal \mathfrak{m} of a standard graded K -algebra.

Proposition 1.7. *Let I be a homogeneous ideal of $R[Z]$. Then, there exists a Z -stable ideal J of $R[Z]$ with the same Hilbert function as I such that*

$$\text{Hilb} \left(H_{\mathfrak{m}_{R[Z]}}^i(R[Z]/I) \right) \leq \text{Hilb} \left(H_{\mathfrak{m}_{R[Z]}}^i(R[Z]/J) \right), \quad \text{for all } i.$$

Proof. By [Sb] Theorem 2.4, $\text{Hilb} \left(H_{\mathfrak{m}_{R[Z]}}^i(R[Z]/I) \right) \leq \text{Hilb} \left(H_{\mathfrak{m}_{R[Z]}}^i(R[Z]/\text{in}_\omega(I)) \right)$ where $\omega = (1, \dots, 1, 0)$, and thus without loss of generality we may assume that I is Z -graded. Let now \mathcal{I} be the set of all Z -graded ideals of $R[Z]$ with same Hilbert function as I and $J \in \mathcal{I}$ be maximal - with respect to the partial order \prec defined in (1.5) - among the ideals of \mathcal{I} which satisfy $\text{Hilb} \left(H_{\mathfrak{m}_{R[Z]}}^i(R[Z]/I) \right) \leq \text{Hilb} \left(H_{\mathfrak{m}_{R[Z]}}^i(R[Z]/J) \right)$ for all i . We claim that J is Z -stable. If it were not, by Proposition 1.6 there would exist a positive integer d and a linear form l such that $J \prec \text{in}_\omega(D_{(d,l)}(J))$. By (1.4) together with [Sb] Section 5, we have $\text{Hilb} \left(H_{\mathfrak{m}_{R[Z]}}^i(R[Z]/J) \right) = \text{Hilb} \left(H_{\mathfrak{m}_{R[Z]}}^i(R[Z]/D_{(d,l)}(J)) \right)$. By [Sb] Theorem 2.4, $\text{in}_\omega(D_{(d,l)}(J)) \in \mathcal{I}$, contradicting the maximality of J . \square

2. EMBEDDINGS AND THE GENERAL HYPERPLANE RESTRICTION THEOREM

Let $B = K[X_1, \dots, X_n]$ be a standard graded polynomial ring over a field K , \mathfrak{b} a homogeneous ideal of B and $S = B/\mathfrak{b}$. Denote by \mathcal{I}_S the poset $\{J : J \text{ is a homogeneous } S\text{-ideal}\}$ ordered by inclusion, and with \mathcal{H}_S the poset $\{\text{Hilb}(J)_\bullet : J \in \mathcal{I}_S\}$ of all Hilbert functions of the ideals in \mathcal{I}_S with the usual point-wise partial order. Following [CaKu1] we say that S

admits an embedding if there exists an order preserving injection $\epsilon: \mathcal{H}_S \longrightarrow \mathcal{I}_S$ such that the image of any given Hilbert function is an ideal with that Hilbert function. We call any such ϵ an *embedding of S* . A ring S with a specified embedding ϵ is denoted by (S, ϵ) and, for simplicity's sake, we also let $\epsilon(I) := \epsilon(\text{Hilb}(I)_\bullet)$, for every $I \in \mathcal{I}_S$. The notion of embedding captures the key property of rings for which an analogous of Macaulay Theorem holds.

Example 2.1 (Three standard examples of embedding). In the following we present some results that can be re-interpreted with the above terminology.

(a) Let $S = B$ and define $\epsilon: \mathcal{H}_S \longrightarrow \mathcal{I}_S$ as $\epsilon(\text{Hilb}(I)_\bullet) := L$, where L is the unique lex-segment ideal with Hilbert function $\text{Hilb}(I)_\bullet$. The fact that this map is well-defined is just a restatement of Macaulay Theorem.

(b) Let $S = B/\mathfrak{b}$, where $\mathfrak{b} = (X_1^{d_1}, \dots, X_r^{d_r})$ and $d_1 \leq \dots \leq d_r$. Let I be a homogeneous ideal of S , by Clements-Lindström Theorem [CLLi] there exists a lex-segment ideal $L \subseteq B$ such that $\text{Hilb}(I) = \text{Hilb}(LS)$. Since LS is uniquely determined by $\text{Hilb}(I)$, we may define $\epsilon(\text{Hilb}(I)_\bullet) := LS$. The ideal $L + \mathfrak{b}$, which is uniquely determined by the Hilbert function of I , is often referred to as *the Lex-Plus-Power ideal associated with I (with respect to d_1, \dots, d_r)*.

(c) Let m be a positive integer and $S = B^{(m)} = \bigoplus_{d \geq 0} B_{md}$ the m^{th} -Veronese subring of B . Let I be a homogeneous ideal of S . Then, by [GaPeMu], there exists a lex-segment ideal L of B such that $\text{Hilb}(I) = \text{Hilb}\left(\bigoplus_{d \geq 0} L_{md}\right)$ and we define $\epsilon(\text{Hilb}(I)_\bullet) := \bigoplus_{d \geq 0} L_{md}$.

We observe that in all of the above examples the image set of ϵ consists of the classes in S of lex-segment ideals; rings with this property are called *Macaulay-Lex*, cf. for instance [MePe].

These examples can be derived by general properties of embeddings proved in [CaKu1]. For instance, if we let (S, ϵ) be a ring with an embedding then:

- (i) the polynomial ring $S[Z]$ admits an embedding and if ϵ is defined by means of a lex-segment as in (a) and (b) then so is the extended embedding on $S[Z]$;
- (ii) when $\mathcal{H}_{S[Z]/(Z^d)} = \{\text{Hilb}(JS[Z])_\bullet : J \text{ is } Z\text{-stable}\}$, the ring $S[Z]/(Z^d)$ admits an embedding as well. By an iterated use of this fact, starting with $S = K$, one can recover (b);
- (iii) any Veronese subring $S^{(m)}$ of S admits an embedding inherited from (S, ϵ) ;
- (iv) $S/\epsilon(I)$ admits an embedding induced by ϵ ;
- (v) when \mathfrak{b} is monomial and $\mathfrak{c} \subseteq T$ is a polarization of \mathfrak{b} , then T/\mathfrak{c} admits an embedding. \square

The following theorem generalizes to rings with embedding [HePo] Theorem 3.7 (see also [Ga] Theorem 2.4) valid for polynomial rings.

Theorem 2.2 (General Restriction Theorem). *Let (S, ϵ) be a standard graded K -algebra with an embedding and $S[Z]$ a polynomial ring in one variable with coefficients in S . There exists an embedding $\epsilon_1: \mathcal{H}_{S[Z]} \longrightarrow \mathcal{I}_{S[Z]}$ such that $\epsilon_1(I) = \bigoplus_h J_{(h)} Z^h$ is a Z -stable ideal with $\epsilon(J_{(h)}) = J_{(h)}$. Moreover, if I is Z -stable, then*

$$\text{Hilb}\left(I + (Z^j)\right) \geq \text{Hilb}\left(\epsilon_1(I) + (Z^j)\right), \quad \text{for all } j.$$

Proof. See that of [CaKu1] Theorem 3.9 (see also [CaKu2] Theorem 2.1). \square

Definition 2.3. Let (S, ϵ) be a ring with an embedding. We say that a K -algebra R *embeds into (S, ϵ)* and we write (R, S, ϵ) if $\mathcal{H}_R \subseteq \mathcal{H}_S$. Moreover, we say that an ideal I of S is embedded if it is in the image of ϵ . For simplicity's sake, we let again $\epsilon(I) := \epsilon(\text{Hilb}(I)_\bullet)$ for all homogeneous ideals I of R .

Clearly, (S, ϵ) embeds into itself and if R embeds into (S, ϵ) then $\text{Hilb}(R) = \text{Hilb}(S)$, for there is an ideal $I \in \mathcal{I}_S$ with same Hilbert function as R , therefore $\text{Hilb}(I)_0 = 1$ implies $I = S$.

The above definition is motivated by the conjecture of Eisenbud, Green and Harris, which has been discussed in the introduction. When a regular sequence \mathbf{f} of $A = K[X_1, \dots, X_n]$ satisfies **EGH**, the Hilbert functions of homogeneous ideals in $R = A/(\mathbf{f})$ are also Hilbert functions of homogeneous ideal in $S = B/(X_1^{d_1}, \dots, X_r^{d_r})$. Equivalently $\mathcal{H}_R \subseteq \mathcal{H}_S$. The fact that Clements-Lindström Theorem holds for S tells us that R embeds into S . One of the reasons why **EGH** is important is that $\mathcal{H}_R \subseteq \mathcal{H}_S$ together with the fact that Clements-Lindström Theorem gives an embedding, allow to transfer certain results, e.g. an uniform upper bound on the number of generators as in Remark 2.5), from the ring S to the ring R .

Let now (S, ϵ) be a ring with an embedding, and let $I \in \mathcal{I}_S$. It is easily seen from [CaKu1] Proposition 2.4 and Definition 2.3 (i) that the ideal $\epsilon(I)\mathfrak{m}_S$ is embedded i.e. $\epsilon(\epsilon(I)\mathfrak{m}_S) = \epsilon(I)\mathfrak{m}_S$.

Lemma 2.4. *Let R embed into (S, ϵ) and let $I \in \mathcal{I}_R$. Then, $\mathfrak{m}_S\epsilon(I) \subseteq \epsilon(\mathfrak{m}_R I)$.*

Proof. Since $\mathfrak{m}_S\epsilon(I)$ is embedded and embeddings preserve poset structures we only need to show that $\text{Hilb}(\mathfrak{m}_S\epsilon(I))_{\bullet} \leq \text{Hilb}(\epsilon(\mathfrak{m}_R I))_{\bullet}$ or, equivalently, that $\dim_K(S_1\epsilon(I))_{d+1} \leq \dim_K R_1 I_d$ for all $d \geq 0$. Since $\epsilon(I)$ contains $\epsilon((I_d))$ and they agree in degree d , we have $(S_1\epsilon(I))_{d+1} = (S_1\epsilon((I_d)))_{d+1}$ and its dimension is smaller than or equal to that of $\epsilon((I_d))_{d+1}$. Now it is enough to observe that the latter has the same dimension as $R_1 I_d$. \square

Remark 2.5. There is point-wise inequality between the number and the degrees of minimal generators of a homogeneous ideal $I \subseteq R$ and the ones of $\epsilon(I)$, namely $\beta_{1j}^R(I) \leq \beta_{1j}^S(\epsilon(I))$. This inequality is equivalent to $\text{Hilb}(I/\mathfrak{m}_R I) \leq \text{Hilb}(\epsilon(I)/\mathfrak{m}_S\epsilon(I))$, which follows immediately from Lemma 2.4.

Proposition 2.6. *Let R embed into (S, ϵ) and let ϵ_1 as in Theorem 2.2. Then $R[Z]$ embeds into $(S[Z], \epsilon_1)$. Moreover, if I is a Z -stable ideal of $R[Z]$ then*

$$\text{Hilb}(I + (Z^j)) \geq \text{Hilb}(\epsilon_1(I) + (Z^j)), \quad \text{for all } j.$$

Proof. Let I be a homogeneous ideal of $R[Z]$. By Proposition 1.7 there exists a Z -stable ideal of $R[Z]$ with the same Hilbert function as I so that we may assume that I is Z -stable. Now we write I as $\bigoplus_{h \in \mathbb{N}} I_{(h)} Z^h$ and we let J be the S -module $\bigoplus_{h \in \mathbb{N}} \epsilon(I_{(h)}) Z^h$. It is easy to see that J is an ideal of S , for $\epsilon(I_{(0)}) \subseteq \epsilon(I_{(1)}) \subseteq \dots$, and thus $\mathcal{H}_{R[Z]} \subseteq \mathcal{H}_{S[Z]}$. By Lemma 2.4, $\mathfrak{m}_S\epsilon(I_{(h+1)}) \subseteq \epsilon(I_{(h)})$ which implies that J is Z -stable. We now have $\text{Hilb}(I + (Z^j)) = \text{Hilb}(J + (Z^j))$ for all j and we can conclude the proof by applying Theorem 2.2 since $\epsilon_1(J) = \epsilon_1(I)$. \square

We conclude this section with a technical result we need later on.

Lemma 2.7. *Let R embed into (S, ϵ) and let ϵ_1 as in Theorem 2.2. If I is a Z -stable ideal of $R[Z]$, then $\epsilon(\bar{I})^{\text{sat}} = \overline{\epsilon_1(I)}^{\text{sat}}$.*

Proof. First, we observe that $\overline{\epsilon_1(I)} = \epsilon_1(I)_{(0)}$ is an embedded ideal of R by Theorem 2.2. By Proposition 2.6, $\text{Hilb}(\bar{I})_{\bullet} \geq \text{Hilb}(\overline{\epsilon_1(I)})_{\bullet}$, hence $\epsilon(\bar{I}) \supseteq \overline{\epsilon_1(I)} = \overline{\epsilon_1(I)}$. Moreover,

$\text{Hilb}(\epsilon(\bar{I}))_j = \text{Hilb}(\bar{I})_j = \text{Hilb}(\overline{\epsilon_1(I)})_j$ for $j \gg 0$ by Lemma 1.3, from which we deduce that $\epsilon(\bar{I})_j = \overline{\epsilon_1(I)}_j$ for $j \gg 0$. This is enough to complete the proof, since saturation of a homogeneous ideal can be computed by any of its sufficiently high truncations. \square

3. THE MAIN THEOREM

In this section we illustrate our main result, which is stated in the next theorem. We say that (R, S, ϵ) is *(local) cohomology extremal* if, for every homogeneous ideal I of R and all i , one has $\text{Hilb}(H_{\mathfrak{m}_R}^i(R/I)) \leq \text{Hilb}(H_{\mathfrak{m}_S}^i(S/\epsilon(I)))$.

We recall that both R and S are graded quotients of $A = B = K[X_1, \dots, X_n]$, and that the projective dimension $\text{projdim}_A(M)$ and the Castelnuovo-Mumford regularity $\text{reg}_A(M)$ of a finitely generated graded A -module M can be expressed in terms of local cohomology modules as $\max\{n - i : H_{\mathfrak{m}_A}^i(M) \neq 0\}$ and $\max\{d + i : H_{\mathfrak{m}_A}^i(M)_d \neq 0\}$ respectively. Thus when (R, S, ϵ) is cohomology extremal, for every homogeneous ideal I of R one has

$$\text{projdim}(R/I) \leq \text{projdim}(S/\epsilon(I)) \quad \text{and} \quad \text{reg}(R/I) \leq \text{reg}(S/\epsilon(I)),$$

and analogous inequalities hold for the embeddings ϵ_1 and ϵ_m of Theorem 3.1 and Corollary 3.2 below.

Theorem 3.1. *Let (R, S, ϵ) be cohomology extremal. Then, $(R[Z], S[Z], \epsilon_1)$ is cohomology extremal.*

By recursion, one immediately obtains the natural generalization to the case of m variables.

Corollary 3.2. *Let m be a positive integer and (R, S, ϵ) be cohomology extremal. Then, $(R[Z_1, \dots, Z_m], S[Z_1, \dots, Z_m], \epsilon_m)$ is cohomology extremal.*

Let $A = K[X_1, \dots, X_m]$ be a polynomial ring over a field K , $I \subseteq A$ a homogeneous ideal and L the unique lex-segment ideal of A with the same Hilbert function as I . It was proven in [Sb] Theorem 5.4 that

$$(3.3) \quad \text{Hilb}(H_{\mathfrak{m}_A}^i(A/I)) \leq \text{Hilb}(H_{\mathfrak{m}_A}^i(A/L)), \quad \text{for all } i.$$

This result can be now recovered from the above corollary, since any field K has a trivial embedding ϵ_0 , so that (K, K, ϵ_0) and (A, A, ϵ_m) are cohomology extremal. By Example 2.1 part (i), we know that $\epsilon_m(I)$ is the lex-segment ideal L .

Similarly, Corollary 3.2 implies the following result, which is the analogous inequality, for local cohomology, of that for Betti numbers proved by Mermin and Murai in [MeMu].

Theorem 3.4. *Let $A = K[X_1, \dots, X_n]$, $\mathfrak{a} = (X_1^{d_1}, \dots, X_r^{d_r})$, with $d_1 \leq \dots \leq d_r$. Let $I \subseteq A$ be a homogeneous ideal containing \mathfrak{a} , and let $L + \mathfrak{a}$ be the Lex-Plus-Power ideal associated to I with respect to d_1, \dots, d_r . Then,*

$$(3.5) \quad \text{Hilb}(H_{\mathfrak{m}_A}^i(A/I)) \leq \text{Hilb}(H_{\mathfrak{m}_A}^i(A/L + \mathfrak{a})), \quad \text{for all } i.$$

Proof. Let $\bar{R} = K[X_1, \dots, X_r]/(X_1^{d_1}, \dots, X_r^{d_r})$; by Example 2.1 (b) \bar{R} has an embedding ϵ induced by the Clements and Lindström Theorem. Since \bar{R} is Artinian we see immediately that $(\bar{R}, \bar{R}, \epsilon)$ is cohomology extremal being $H_{\mathfrak{m}_{\bar{R}}}^0(\bar{R}/J) = \bar{R}/J$ and $H_{\mathfrak{m}_{\bar{R}}}^0(\bar{R}/\epsilon(J)) = \bar{R}/\epsilon(J)$

for all homogeneous ideal J of \bar{R} . Now, A/\mathfrak{a} is isomorphic to $\bar{R}[X_{r+1}, \dots, X_n]$, and by Corollary 3.2 we know that ϵ_{n-r} is cohomology extremal. Furthermore, $\epsilon_{n-r}(I(A/\mathfrak{a})) = L(A/\mathfrak{a})$ (see [CaKu2] Remark 2.5). By Base Independence of local cohomology, we thus have

$$\begin{aligned} \text{Hilb} \left(H_{\mathfrak{m}_A}^i(A/I) \right) &= \text{Hilb} \left(H_{\mathfrak{m}_{A/\mathfrak{a}}}^i(A/I) \right) \\ &\leq \text{Hilb} \left(H_{\mathfrak{m}_{A/\mathfrak{a}}}^i((A/\mathfrak{a})/\epsilon_{n-r}(I(A/\mathfrak{a}))) \right) \\ &= \text{Hilb} \left(H_{\mathfrak{m}_A}^i(A/L + \mathfrak{a}) \right), \quad \text{for all } i. \end{aligned}$$

□

For the proof of Theorem 3.1 we need some preparatory facts. First, we observe that for any homogeneous ideal I of $R[Z]$,

$$(3.6) \quad \overline{I^{\text{sat}}}^{\text{sat}} = \bar{I}^{\text{sat}},$$

since $\overline{I^{\text{sat}}}$ and \bar{I} coincide in high degrees because I^{sat} and I do.

It is not difficult to see that, if I is a homogeneous ideal of R , then for all $i > 0$

$$\text{Hilb} \left(H_{\mathfrak{m}_{R[Z]}}^i(R[Z]/IR[Z]) \right)_h = \sum_{k \geq h} \text{Hilb} \left(H_{\mathfrak{m}_R}^{i-1}(R/I) \right)_{k+1},$$

cf. for instance [Sb2] Lemma 2.2 for a proof. As an application, when I is a Z -stable ideal of $R[Z]$ and $i > 0$ one has

$$(3.7) \quad \text{Hilb} \left(H_{\mathfrak{m}_{R[Z]}}^i(R[Z]/I) \right)_h = \text{Hilb} \left(H_{\mathfrak{m}_{R[Z]}}^i(R[Z]/I^{\text{sat}}) \right)_h = \sum_{k \geq h} \text{Hilb} \left(H_{\mathfrak{m}_R}^{i-1}(R/\bar{I}^{\text{sat}}) \right)_{k+1},$$

which is clearly equivalent to

$$(3.8) \quad \text{Hilb} \left(H_{\mathfrak{m}_{R[Z]}}^i(R[Z]/I) \right) = \sum_{j < 0} t^j \cdot \text{Hilb} \left(H_{\mathfrak{m}_R}^{i-1}(R/\bar{I}^{\text{sat}}) \right), \quad \text{for } i > 0.$$

We shall also need the observation, yielded by (3.8) together with (3.6), that for a Z -stable ideal I of $R[Z]$

$$(3.9) \quad \text{Hilb} \left(H_{\mathfrak{m}_{R[Z]}}^i(R[Z]/I) \right) = \sum_{j < 0} t^j \cdot \text{Hilb} \left(H_{\mathfrak{m}_R}^{i-1}(R/\bar{I}^{\text{sat}}) \right), \quad \text{for } i > 1.$$

Lemma 3.10. *Let I be a Z -stable ideal of $S[Z]$ and $d \gg 0$ a fixed integer. Then, for all $j = 0, \dots, d$,*

$$\sum_{k=0}^j \text{Hilb} \left(\overline{I^{\text{sat}}} \right)_{d-k} \leq \sum_{k=0}^j \text{Hilb} \left(\overline{\epsilon_1(I)^{\text{sat}}} \right)_{d-k}.$$

Proof. Let $I_d = V_d \oplus V_{d-1}Z_m \oplus \dots \oplus V_0Z_m^d$ be a decomposition of I_d as a direct sum of vector spaces. Since $d \gg 0$, we have that $I^{\text{sat}} = (I_d)^{\text{sat}}$ which by Z -stability is $(I_d) : Z_m^\infty$; therefore, I^{sat} is generated by the elements in $V_0 \oplus \dots \oplus V_d$, which also generate in S the ideal $\overline{I^{\text{sat}}}$. Moreover, cf. Remark 1.2(a), $(\overline{I^{\text{sat}}})_{d-j}$ is exactly the vector space V_j , for $0 \leq j \leq d$. The same argument can be repeated for $\epsilon_1(I)$, since it is also Z -stable; therefore, the two terms which appear in the inequality that has to be proven are the values at d of the Hilbert function of $I + (Z_m)^j / (Z_m)^j$ and $\epsilon_1(I) + (Z_m)^j / (Z_m)^j$ respectively, thus the conclusion follows now immediately from Theorem 2.2. □

Proof of Theorem 3.1. By Proposition 1.7 we may assume I to be Z -stable in order to prove our thesis

$$\mathrm{Hilb} \left(H_{\mathfrak{m}_{R[Z]}}^i (R[Z]/I) \right) \leq \mathrm{Hilb} \left(H_{\mathfrak{m}_{S[Z]}}^i (S[Z]/\epsilon_1(I)) \right), \quad \text{for all } i.$$

$\boxed{i = 0}$ For this case it is enough to recall that $\mathrm{Hilb} (R[Z]/I) = \mathrm{Hilb} (S[Z]/\epsilon_1(I))$ and Proposition 2.2 yields $\mathrm{Hilb} (R[Z]/(I + (Z^j))) \leq \mathrm{Hilb} (S[Z]/(\epsilon_1(I) + (Z^j)))$, for all j . Thus, for all j , $\mathrm{Hilb} (I : Z^j/I) \leq \mathrm{Hilb} (\epsilon_1(I) : Z^j/\epsilon_1(I))$ which is equivalent to our thesis if j is chosen to be large enough, as we already observed in Remark 1.2 (b).

$\boxed{i = 1}$ If $H_{\mathfrak{m}_{R[Z]}}^1 (R[Z]/I) = 0$ there is nothing to prove. Suppose then that this is not the case. Now, an application of (3.7) with $d \gg 0$ and for all $j \leq d$ yields

$$\begin{aligned} \mathrm{Hilb} \left(H_{\mathfrak{m}_{R[Z]}}^1 (R[Z]/I) \right)_{d-j} &= \sum_{k=0}^j \mathrm{Hilb} \left(H_{\mathfrak{m}_R}^0 (R/\overline{I}^{\mathrm{sat}}) \right)_{d+1-k} \\ (3.11) \qquad \qquad \qquad &= \underbrace{\sum_{k=0}^j \mathrm{Hilb} \left(\overline{I}^{\mathrm{sat}} \mathrm{sat} \right)_{d+1-k}}_{\Sigma_1(I)} - \underbrace{\sum_{k=0}^j \mathrm{Hilb} \left(\overline{I}^{\mathrm{sat}} \right)_{d+1-k}}_{\Sigma_2(I)}. \end{aligned}$$

We now look at the terms appearing in the first sum. By Lemma 2.7, $\epsilon(\overline{I})^{\mathrm{sat}}$ and $\overline{\epsilon_1(I)}^{\mathrm{sat}}$ are equal, and thus (3.6) implies

$$\begin{aligned} \Sigma_1(I) &= \sum_{k=0}^j \mathrm{Hilb} \left(\overline{I}^{\mathrm{sat}} \mathrm{sat} \right)_{d+1-k} = \sum_{k=0}^j \mathrm{Hilb} \left(\overline{I}^{\mathrm{sat}} \right)_{d+1-k} \leq \sum_{k=0}^j \mathrm{Hilb} \left(\epsilon(\overline{I})^{\mathrm{sat}} \right)_{d+1-k} \\ (3.12) \qquad \qquad \qquad &= \sum_{k=0}^j \mathrm{Hilb} \left(\overline{\epsilon_1(I)}^{\mathrm{sat}} \right)_{d+1-k} = \Sigma_1(\epsilon_1(I)), \end{aligned}$$

for $\mathrm{Hilb} \left(\overline{I}^{\mathrm{sat}} \right) \leq \mathrm{Hilb} \left(\epsilon(\overline{I})^{\mathrm{sat}} \right)$ descends easily from the fact that (R, S, ϵ) is cohomology extremal considering cohomological degree 0. Since $\Sigma_2(I) \geq \Sigma_2(\epsilon_1(I))$ by Lemma 3.10, (3.12) now implies

$$\begin{aligned} \mathrm{Hilb} \left(H_{\mathfrak{m}_{R[Z]}}^1 (R[Z]/I) \right)_{d-j} &= \Sigma_1(I) - \Sigma_2(I) \\ &\leq \Sigma_1(\epsilon_1(I)) - \Sigma_2(\epsilon_1(I)) = \mathrm{Hilb} \left(H_{\mathfrak{m}_{S[Z]}}^1 (S[Z]/\epsilon_1(I)) \right)_{d-j} \end{aligned}$$

and this case is completed.

$\boxed{i > 1}$ By (3.9) and being $\sum_{j < 0} t^j$ a series with positive coefficients, we are left to prove the inequality $\mathrm{Hilb} \left(H_{\mathfrak{m}_R}^i (R/\overline{I}^{\mathrm{sat}}) \right) \leq \mathrm{Hilb} \left(H_{\mathfrak{m}_S}^i (S/\overline{\epsilon_1(I)}^{\mathrm{sat}}) \right)$ for all $i > 0$, or its equivalent $\mathrm{Hilb} \left(H_{\mathfrak{m}_R}^i (R/\overline{I}) \right) \leq \mathrm{Hilb} \left(H_{\mathfrak{m}_S}^i (S/\overline{\epsilon_1(I)}) \right)$ for $i > 0$. By hypothesis, $\mathrm{Hilb} \left(H_{\mathfrak{m}_R}^i (R/\overline{I}) \right) \leq \mathrm{Hilb} \left(H_{\mathfrak{m}_S}^i (S/\overline{\epsilon(I)}) \right)$ for all $i > 0$, thus we may conclude if we know, and we do by Lemma 2.7, that $\epsilon(\overline{I})$ and $\overline{\epsilon_1(I)}$ have the same saturation.

Now the proof of the theorem is complete. \square

4. A LEX-PLUS-POWER-TYPE INEQUALITY FOR LOCAL COHOMOLOGY

Let $A = B = K[X_1, \dots, X_n]$, let $\mathfrak{a} = (\mathbf{f}) = (f_1, \dots, f_r)$ be the ideal of A generated by a homogeneous regular sequence f_1, \dots, f_r of degrees $d_1 \leq \dots \leq d_r$, and let $\mathfrak{b} \subseteq B$ be the ideal $(X_1^{d_1}, \dots, X_r^{d_r})$. As before, we let $R = A/\mathfrak{a}$ and $S = B/\mathfrak{b}$ and recall that, by Clements-Lindström Theorem, S has an embedding whose image set consists of the classes in S of all lex-segment ideals of B . Henceforth, such an embedding will be denoted by ϵ_{CL} . Thus, we may restate **EGH** in the following way.

Conjecture 4.1 (Eisenbud-Green-Harris). Let \mathbf{f} be as above. Then, R embeds into $(S, \epsilon_{\text{CL}})$.

At the moment there are few cases for which a proof of this conjecture is known, and are essentially contained in [CilLi], [CaMa], [Ch] and [Ab]. Yet, Evans wondered if the following far-reaching result on graded Betti numbers holds.

Conjecture 4.2 (Evans' **LPP**). Assume that \mathbf{f} satisfies **EGH**. Then, for all homogeneous ideal I of R and all i

$$\beta_{ij}^A(R/I) := \text{Hilb} \left(\text{Tor}_i^A(R/I, K) \right)_j \leq \text{Hilb} \left(\text{Tor}_i^B(S/\epsilon_{\text{CL}}(I), K) \right)_j =: \beta_{ij}^B(S/\epsilon_{\text{CL}}(I)).$$

Remark 4.3. Consistently with our definition of cohomology extremal embeddings, we will call an embedding (R, S, ϵ) satisfying the inequality predicted by the **LPP** conjecture above, *Betti extremal*. With this terminology, Theorem 3.1 of [CaKu2] together with the subsequent discussion imply that, when (R, S, ϵ) is Betti extremal, $(R[Z], S[Z], \epsilon_1)$ is Betti extremal as well.

The only case in which **LPP** is known so far is when \mathbf{f} is monomial, see [MePeSt] for a proof when $d_1 = \dots = d_r = 2$ and [MeMu] for a proof without restrictions on the degrees. The purpose of this section is to prove in Theorem 4.4 an analogous of the **LPP** conjecture when we consider local cohomology modules instead of Tor modules. Theorem 4.4 holds not only when \mathbf{f} is monomial but also in all the cases for which **EGH** is known. More precisely, our assumption is to require that at least an Artinian reduction of $A/(\mathbf{f})$ satisfies **EGH**.

Let l_1, \dots, l_{n-r} be a sequence of linear forms such that $\mathbf{f}, l_1, \dots, l_{n-r}$ form an A -regular sequence, which always exists provided that K is infinite. After applying a coordinates change we may assume these linear forms to be X_n, \dots, X_{r+1} . Let $\bar{\mathbf{f}} \in \bar{A} = K[X_1, \dots, X_r]$ be the image of \mathbf{f} modulo X_n, \dots, X_{r+1} . We also let $\bar{B} = \bar{A}$ and $\bar{\mathfrak{b}}$ be the image of \mathfrak{b} in \bar{B} . Finally, $\bar{\epsilon}_{\text{CL}}$ will denote the Clements-Lindström embedding of $\bar{B}/\bar{\mathfrak{b}}$.

Theorem 4.4. Assume that $\bar{\mathbf{f}}$ satisfies **EGH**. Then, for all homogeneous ideal I of R .

$$\text{Hilb} \left(H_{\mathfrak{m}_R}^i(R/I) \right) \leq \text{Hilb} \left(H_{\mathfrak{m}_S}^i(S/\epsilon_{\text{CL}}(I)) \right).$$

In other words, $(R, S, \epsilon_{\text{CL}}(I))$ is cohomology extremal.

Proof. Let I be a homogeneous ideal of R and let J denote its pre-image in A . Clearly, $(\mathbf{f}) \subseteq J$ and, if we let ω be the weight vector with entries $\omega_i = 1$ for all $i \leq r$ and 0 otherwise, then $\mathbf{f} \in P := \text{in}_\omega(J)$. By hypothesis $\bar{A}/(\bar{\mathbf{f}})$ embeds into $(\bar{B}/\bar{\mathfrak{b}}, \bar{\epsilon}_{\text{CL}})$, and moreover being both rings Artinian $(\bar{A}/(\bar{\mathbf{f}}), \bar{B}/\bar{\mathfrak{b}}, \bar{\epsilon}_{\text{CL}})$ is trivially cohomology extremal. Theorem 3.1 now yields that $(A/(\bar{\mathbf{f}})A, S, \epsilon)$ is also cohomology extremal and ϵ , which is obtained

by extending $\bar{\epsilon}_{\text{CL}}$, is precisely the Clements-Lindström embedding ϵ_{CL} of S , cf. Example 2.1 part (ii). By Base Independence of local cohomology and by [Sb] Theorem 2.4, $\text{Hilb}\left(H_{\mathfrak{m}_R}^i(R/I)\right) = \text{Hilb}\left(H_{\mathfrak{m}_A}^i(A/J)\right) \leq \text{Hilb}\left(H_{\mathfrak{m}_{A/(\bar{\mathbf{f}})A}}^i(A/P)\right)$. Finally, since I has the same Hilbert function as the image of P in $A/(\bar{\mathbf{f}})A$ and $(A/(\bar{\mathbf{f}})A, S, \epsilon_{\text{CL}})$ is cohomology extremal, we have $\text{Hilb}\left(H_{\mathfrak{m}_{A/(\bar{\mathbf{f}})A}}^i(A/P)\right) \leq \text{Hilb}\left(H_{\mathfrak{m}_S}^i(S/\epsilon_{\text{CL}}(I))\right)$ as desired. \square

Remark 4.5. Clearly, if **EGH** were true in general then the assumption on $\bar{\mathbf{f}}$ in Theorem 4.4 would be trivially satisfied and $(R, S, \epsilon_{\text{CL}})$ would be cohomology extremal. It is proven in [CaMa] that if $\bar{\mathbf{f}}$ satisfies **EGH** then \mathbf{f} does, whereas at this point we do not know about the converse. A simple flat deformation argument together with the results of [MeMu] and [MePeSt] shows that **LPP** holds true when \mathbf{f} is a Gröbner basis with respect to some given term order τ . We would like to point out that, under this assumption, the conclusion of Theorem 4.4 holds as well, and we prove our claim in the following lines. Let $\mathbf{g} = \text{in}_\tau(f_1), \dots, \text{in}_\tau(f_r)$. As in the proof of Theorem 4.4, by [Sb] Theorem 2.4 it is sufficient to bound above $\text{Hilb}\left(H_{\mathfrak{m}_{A/(\mathbf{g})}}^i(A/\text{in}_\tau((\mathbf{f}) + I))\right)$. By hypothesis \mathbf{g} form a monomial regular sequence in A , therefore it is easy to see that there are linear forms l_1, \dots, l_{n-r} such that $A/(\mathbf{g}, l_1, \dots, l_{n-r})$ is Artinian and isomorphic to $K[X_1, \dots, X_r]/(X_1^{d_1}, \dots, X_r^{d_r})$, which has the Clements-Lindström embedding. Therefore, the sequence $\bar{\mathbf{g}}$ in $A/(l_1, \dots, l_{n-r})$ satisfies **EGH**, and thus, verifies the hypothesis of Theorem 4.4, which now yields what we wanted.

5. EXTREMAL BETTI NUMBERS AND **LPP**

In this section we show how to derive directly from Theorem 4.4 a special case of **LPP** for Betti numbers. Precisely, we prove that the inequality predicted by **LPP** holds for those Betti numbers which in the literature, following [BaChPo], are called *extremal*. Furthermore, we will show an inclusion between the regions of the Betti tables of R/I and S/ϵ_{CL} where non-zero values may appear, and which are outlined by the positions of the corresponding extremal Betti numbers.

As in the previous section, let $\mathbf{f} \in A = K[X_1, \dots, X_n]$ be a homogeneous regular sequence of degrees $d_1 \leq \dots \leq d_r$. By extending the field we may assume that $|K| = \infty$ and up to a change of coordinates, that $\mathbf{f}, X_n, \dots, X_{n-r+1}$ form a regular sequence as well. Let M be a finitely generated graded A -module; the following definition was introduced in [BaChPo] when $M = A/I$. A non-zero $\beta_{ij}^A(M) = \dim_K \text{Tor}_i^A(M, K)_j$ such that $\beta_{rs}(M) = 0$ whenever $r \geq i, s \geq j + 1$ and $s - r \geq j - i$ is called *extremal Betti number* of M . A pair of indexes $(i, j - i)$ such that $\beta_{ij}(M)$ is extremal is called a *corner* of M . The reason for this terminology is that extremal Betti numbers correspond to certain corners in the output of Macaulay2 [M2] command for computing Betti diagrams. Let I be a homogeneous ideal of A and denote by $\text{Gin}(I)$ the generic initial ideal of I with respect to the reverse lexicographic order, cf. [Gr2] and [Ei] for more details on generic initial ideals. The interest in extremal Betti numbers comes from the fact, proved in [BaChPo] and [Tr], that A/I and $A/\text{Gin}(I)$ have the same extremal Betti numbers, and therefore same corners. Since projective dimension and Castelnuovo-Mumford regularity can be computed from corners, this result is a strengthening of the well-known Bayer-Stillman Criterion [BaSt]. In the proof, one can use the fact that

the extremal Betti numbers of M can be computed directly from the Hilbert functions of certain local cohomology modules, and in particular from the considerations in [BaChPo] or [Tr] one can deduce that, for any finitely generated graded A -module M

$$(5.1) \quad \beta_{ij}^A(M) = \text{Hilb} \left(H_{\mathfrak{m}_A}^{n-i}(M) \right)_{j-n},$$

when $(i, j - i)$ is a corner of M .

For the proof of the next theorem, we need to recall the definition of partial Castelnuovo-Mumford regularities and its characterization: Given a finitely generated A -module M , for any integer $0 \leq h \leq \dim M$, we have

$$\text{reg}_h(M) := \sup\{j - i : \beta_{ij}^A(M) \neq 0, i \geq n - h\} = \sup\{j + i : (H_{\mathfrak{m}_A}^i(M))_j \neq 0, i \leq h\},$$

see [Tr] Theorem 3.1 (i). If we set $\text{reg}_{-1}(M) = -\infty$, clearly we have $\text{reg}_{-1}(M) \leq \text{reg}_0(M) \leq \text{reg}_1(M) \leq \dots \leq \text{reg}_n(M) = \text{reg}(M)$. Moreover, the corners of the Betti table of M can be determined by looking at the strict inequalities in the previous sequence: $(i, j - i)$ is a corner of M if and only if

$$(5.2) \quad \text{reg}_{n-i-1}(M) < \text{reg}_{n-i}(M) \quad \text{and} \quad j - i = \text{reg}_{n-i}(M);$$

in particular

$$(5.3) \quad \text{reg}_h(M) = \sup\{j - i : (i, j - i) \text{ is a corner of } M \text{ and } i \geq n - h\}.$$

Theorem 5.4 (LPP for extremal Betti numbers). *Let $\bar{\mathbf{f}}$ satisfy EGH. Then, for all homogeneous ideals I of R ,*

$$\beta_{ij}^A(R/I) \leq \beta_{ij}^A(S/\epsilon_{\text{CL}}(I)),$$

when $(i, j - i)$ is a corner of $S/\epsilon_{\text{CL}}(I)$.

Proof. If $n = 1$ there is nothing to prove. Thus, let $n \geq 2$ and observe that, if $(i, j - i)$ is also a corner of R/I then the conclusion is straightforward by the use of Theorem 4.4 and (5.1). Otherwise, since Theorem 4.4 yields $\text{reg}_h(R/I) \leq \text{reg}_h(S/\epsilon_{\text{CL}}(I))$ for all h , then $\text{reg}_{n-i}(R/I) < \text{reg}_{n-i}(S/\epsilon_{\text{CL}}(I)) = j - i$. Hence $\beta_{ij}^A(R/I) = 0$. \square

Furthermore, under the same assumption of the above theorem, we have the following result, see also Figure 1.

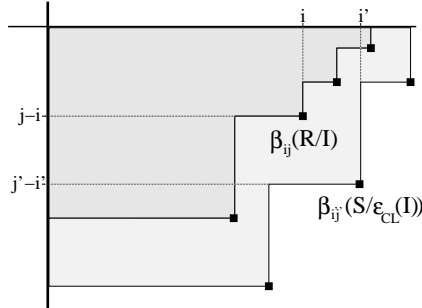

FIGURE 1. The Betti diagrams of R/I and $S/\epsilon_{\text{CL}}(I)$, and their extremal Betti numbers.

Theorem 5.5 (Inclusion of Betti regions). *Let $(i, j - i)$ be a corner of R/I . Then there exists a corner $(i', j' - i')$ of $S/\epsilon_{\text{CL}}(I)$ such that $i \leq i'$ and $j - i \leq j' - i'$.*

Proof. Theorem 4.4 implies that $\text{reg}_h(R/I) \leq \text{reg}_h(S/\epsilon_{\text{CL}}(I))$ for all h . Since $(i, j - i)$ is a corner of R/I , by (5.2) $\text{reg}_{n-i}(R/I) = j - i$ and, therefore, $\text{reg}_{n-i}(S/\epsilon_{\text{CL}}(I)) \geq j - i$. By (5.3) we know that $\text{reg}_{n-i}(S/\epsilon_{\text{CL}}(I)) = j' - i'$ for some corner $(i', j' - i')$ of $S/\epsilon_{\text{CL}}(I)$ satisfying $i' \geq n - (n - i) = i$, as we desired. \square

REFERENCES

- [Ab] A. Abedelfatah. “On the Eisenbud-Green-Harris Conjecture”. arXiv:1212.2653v1 [math.AC].
- [ArHeHi1] A. Aramova, J. Herzog, T. Hibi. “Ideals with stable Betti numbers”. Adv. Math. 152 (2000), no. 1, 72-77.
- [ArHeHi2] A. Aramova, J. Herzog, T. Hibi. “Shifting operations and graded Betti numbers”. J. Algebraic Combin. 12 (2000), no. 3, 207-222.
- [BaChPo] D. Bayer, H. Charalambous, S. Popescu. “Extremal Betti numbers and applications to monomial ideals”. J. Algebra 221 (1999), no. 2, 497-512.
- [BaSt] D. Bayer, M. Stillman. “A criterion for detecting m -regularity”. Invent. Math. 87 (1987), no. 1, 1-11.
- [Bi] A. M. Bigatti. “Upper bounds for the Betti numbers of a given Hilbert function”. Comm. Algebra 21 (1993), no. 7, 2317-2334
- [BiCoRo] A. M. Bigatti, A. Conca, R. Robbiano. “Generic initial ideals and distractions”. Comm. Algebra 33 (2005), no. 6, 1709-1732.
- [BrHe] W. Bruns, J. Herzog. *Cohen-Macaulay rings. Revised edition* Cambridge University Press, Cambridge, 1998.
- [BrSh] M. Brodmann, R. Sharp. *Local Cohomology*. Cambridge University Press, Cambridge, 1998.
- [CaKu1] G. Caviglia, M. Kummini. “Poset embeddings of Hilbert functions”. Math Z. (2012), doi: 10.1007/s00209-012-1097-6.
- [CaKu2] G. Caviglia, M. Kummini. “Embeddings of Hilbert functions and Betti numbers”. arXiv:1210.5562v1 [math.AC].
- [CaMa] G. Caviglia, D. Maclagan. “Some cases of the Eisenbud-Green-Harris conjecture”. Math. Res. Lett. 15 (2008), no. 3, 427-433.
- [Ch] R. Chen. “Hilbert Functions and Free Resolutions”. Ph.D. Thesis, Cornell 2011.
- [CLi] G. F. Clements, B. Lindström. “A generalization of a combinatorial theorem of Macaulay”. J. Combinatorial Theory 7 (1969), 230-238.
- [Ei] D. Eisenbud. *Commutative algebra with a view towards algebraic geometry*. Springer Verlag, New York, 1995.
- [EiGrHa1] D. Eisenbud, M. Green, and J. Harris. “Higher Castelnuovo theory”, in Journées de Géométrie Algébrique d’Orsay (Orsay, 1992). Astérisque (1993), no. 218, 187-202.
- [EiGrHa2] D. Eisenbud, M. Green, and J. Harris. “Cayley-Bacharach theorems and conjectures”. Bull. Amer. Math. Soc. 33 (1996), no. 3, 295-324.
- [Fr] C. A. Francisco. “Almost complete intersections and the lex-plus-powers conjecture”. J. Algebra 276 (2004), no. 2, 737-760.
- [FrRi] C. A. Francisco, B. P. Richert. “Lex-plus-power ideals”, in Syzygies and Hilbert functions, 113-144, Lect. Notes Pure Appl. Math., 254, Chapman & Hall/CRC, Boca Raton, FL, 2007.
- [Ga] V. Gasharov. “Hilbert functions and homogeneous generic forms II”. Compositio Math. 116 (1999), no. 2, 167-172.
- [GaPeMu] V. Gasharov, I. Peeva, S. Murai. “Hilbert schemes and maximal Betti numbers over Veronese rings” Math. Z., 267 (2011), no. 1-2, 155-172.
- [Gr] M. Green. “Restrictions of linear series to hyperplanes, and some results of Macaulay and Gotzmann”, in Algebraic curves and projective geometry (Trento, 1988). Lecture Notes in Math., 1389, 76-86, Springer, Berlin, 1989.

- [Gr2] M. Green. “Generic initial ideals”, *in* Six lectures on Commutative Algebra (J. Elias et. al. eds), 119-186 (2010), Birkhäuser Verlag AG, Basel, 2010.
- [HePo] J. Herzog, D. Popescu. “Hilbert functions and generic forms”. *Compositio Math.* 113 (1998), no. 1, 1-22.
- [HeSb] J. Herzog, E. Sbarra. “Sequentially Cohen-Macaulay modules and local cohomology”, *in* Algebra, arithmetic and geometry, Part I, II (Mumbai, 2000) Tata Inst. Fund. Res., Bombay (2002), 327-340.
- [Hu] H. A. Hulett. “Maximum Betti numbers of homogeneous ideals with a given Hilbert function”. *Comm. Algebra* 21 (1993), no. 7, 2335-2350.
- [Ka] G. Katona. “A theorem for finite sets”, *in* Theory of Graphs (P. Erdős and G. Katona, eds), Academic Press, New York (1968), 187-207.
- [Kr] J. Kruskal. “The number of simplices in a complex”, *em* in Mathematical Optimization Techniques (R. Bellman, ed), University of California Press, Berkeley (1963), 251-278.
- [Ma] F. Macaulay. “Some properties of enumeration in the theory of modular systems”. *Proc. London Math. Soc.* 26 (1927), no. 1, 531-555.
- [M2] D. R. Gruson, M. Stillman. Macaulay 2, a software system for research in algebraic geometry (2006). Available at <http://www.math.uiuc.edu/Macaulay2/>.
- [MeMu] J. Mermin, S. Murai. “The Lex-Plus-Powers Conjecture holds for pure powers”. *Adv. Math.* 226 (2011), no. 4, 3511-3539.
- [MePe] J. Mermin, I. Peeva. “Lexifying ideals”. *Math. Res. Lett.* 13 (2006), no 2-3, 409-422.
- [MePeSt] J. Mermin, I. Peeva, M. Stillman. “Ideals containing the squares of the variables”. *Adv. Math.* 217 (2008), no. 5, 2206-2230.
- [Pa] K. Pardue. “Deformation classes of graded modules and maximal Betti numbers”. *Illinois J. Math.* 40 (1996), no. 4, 564-585.
- [Pe] I. Petrakiev. “On zero-dimensional schemes with special Hilbert functions”. Ph.D. Thesis, Harvard, 2006.
- [PeSt] I. Peeva, M. Stillman. “Open problems on syzygies and Hilbert functions”, available online at: <http://www.math.cornell.edu/~irena/papers/overview.pdf>. *J. Commut. Algebra*, 1 (2009), no. 1, 159-195.
- [Ri] B. P. Richert. “A Study of the Lex Plus Powers Conjecture”. *J. Pure Appl. Algebra*, 186 (2004), no. 2, 169-183.
- [RiSa] B. P. Richert, S. Sabourin. “The residuals of lex plus powers ideals and the Eisenbud-Green-Harris conjecture”. *Illinois J. Math.*, 52 (2008), no. 4, 1355-1384.
- [Sb] E. Sbarra. “Upper bounds for local cohomology for rings with given Hilbert function”. *Comm. Algebra*, 29 (2001), no. 12, 5383-5409.
- [Sb2] E. Sbarra. “Ideals with maximal local cohomology”. *Rend. Sem. Mat. Univ. Padova*, 111 (2004), 265-275.
- [Tr] N. V. Trung. “Gröbner bases, local cohomology and reduction number”. *Proc. Amer. Math. Soc.*, 129 (2001), no. 1, 9-18.

GIULIO CAVIGLIA - DEPARTMENT OF MATHEMATICS - PURDUE UNIVERSITY - 150 N. UNIVERSITY STREET, WEST LAFAYETTE - IN 47907-2067 - USA

E-mail address: gcavigli@math.purdue.edu

ENRICO SBARRA - DIPARTIMENTO DI MATEMATICA - UNIVERSITÀ DEGLI STUDI DI PISA - LARGO BRUNO PONTECORVO 5 - 56127 PISA - ITALY

E-mail address: sbarra@dm.unipi.it