

MA 16200: First Midterm Examination

Spring 2024, Purdue University

Exam version: 01

Name: _____

PUID #: _____

Instruction:

- Follow these instructions carefully. Failure to do so may result in your exam being invalidated and/or an academic integrity violation. All suspected violation of academic integrity will be reported to the Office of the Dean of Students.
- Mark your recitation section below. Write your name and PUID on the top of this cover page. **DO NOT WRITE ANYTHING ELSE** on this cover sheet.

✓	Sec #	Time	TA Name
	0027	7:30AM	Nathan Kapsin
	0050	7:30AM	Brian Wen
	0028	8:30AM	Nathan Kapsin
	0029	8:30AM	Brian Wen
	0048	8:30AM	Sina Nadi
	0052	8:30AM	Ali Sheikh
	0046	8:30AM	Aaron Thomas
	0049	9:30AM	Sina Nadi
	0053	9:30AM	Ali Sheikh
	0047	9:30AM	Aaron Thomas
	0051	10:30AM	Mohit Pandiya
	0032	11:30AM	Mohit Pandiya

✓	Sec #	Time	TA Name
	0016	12:30PM	Tanmay Devale
	0018	12:30PM	Risa Fines
	0023	12:30PM	Cian Nolan
	0015	1:30PM	Tanmay Devale
	0017	1:30PM	Risa Fines
	0024	1:30PM	Cian Nolan
	0031	1:30PM	Mary Collins
	0030	2:30PM	Mary Collins
	0014	2:30PM	Madison Sullivan
	0013	3:30PM	Madison Sullivan
	0025	3:30PM	Conner Partaker
	0026	4:30PM	Conner Partaker

- Use a **#2 PENCIL** to mark the scantron sheet. Fill in the following information:
 - **Your Name:** If there are not enough spaces, fill in as much as you can.
 - **Section Number:** Use all four digits as indicated in the table above.
 - **Test Number:** Fill in 01 for this version of exam.
 - **Student Identification Number:** Fill in your 10-digit PUID with two leading zeros.
 - Write down your TA's name and sign the scantron sheet.
 - Black in your answers in the spaces provided for questions 1–12.
- Do not open the exam booklet or start writing before the proctor signals the start of the exam.
- Do all your work in this exam booklet. Use the back sides of the exam booklet for scratch work.
- Calculators, electronic devices, books, or notes are **NOT ALLOWED**.
- Students may not look at anybody else's exam, and may not communicate with anybody else except with their TA or instructor if there is a question.
- Turn in both the scantron sheet and the exam booklet when you are finished.
- If you finish the exam before 7:25 pm, you may leave the room after turning in the scantron sheet and the exam booklet. You may not leave the room before 6:50 pm. If you don't finish before 7:25 pm, **YOU MUST REMAIN SEATED** until your TA comes and collects your scantron sheet and your exam booklet. You must stop working when the proctor signals the end of exam.

This exam consists of 12 questions. Each question is worth the same number of points. You have exactly one hour to finish the exam. Good luck!

Questions:

1. Consider the sphere $(x - 1)^2 + (y - 2)^2 + (z + 4)^2 = 9$. Which of the following is true?
 - (A) The sphere intersects the xy -plane but not the yz -plane or the xz -plane.
 - (B) The sphere intersects the xy -plane and the yz -plane but does not intersect the xz -plane.
 - (C) The sphere intersects the xz -plane but not the yz -plane or the xy -plane.
 - (D) The sphere intersects the xz -plane and the yz -plane but does not intersect the xy -plane.
 - (E) The sphere intersects the xz -plane and the xy -plane but does not intersect the yz -plane.

2. A cubic tank whose sides are 1 m long sits on the ground and is filled with a liquid of density 100 kg/m^3 . Assume gravitational acceleration $g = 10 \text{ m/s}^2$, compute the the total force on one of its side walls due to pressure.
 - (A) 300 N
 - (B) 500 N
 - (C) 800 N
 - (D) 200 N
 - (E) 400 N

3. Find the area of the region enclosed by $x = y^2$ and $x = 8 - y^2$.

- (A) $\frac{8}{3}$
- (B) $\frac{16}{3}$
- (C) $\frac{64}{3}$
- (D) $\frac{4}{3}$
- (E) $\frac{32}{3}$

4. An object weighing 30 N is suspended by a spring from the ceiling. The spring is stretched beyond its equilibrium position by 0.1 m due to the weight of the object. How much work is needed to return the spring to its equilibrium position?

- (A) 1.5 J
- (B) 15 J
- (C) 30 J
- (D) 3 J
- (E) 10 J

5. What is the angle between the vectors $\vec{a} = 3\vec{i}$ and $\vec{b} = -\vec{i} - \sqrt{2}\vec{j} + \vec{k}$.

(A) $2\pi/3$

(B) $\pi/3$

(C) 0

(D) $5\pi/6$

(E) $\pi/6$

6. What is the area of the triangle with vertices $(1, 1, 1)$, $(3, -1, 2)$, and $(5, 1, -2)$?

(A) $10\sqrt{2}$

(B) 3

(C) 10

(D) $5\sqrt{2}$

(E) 5

7. Let R be the region bounded by $y = x^2$, $y = 2$, and the y -axis. What is the volume of the solid obtained by revolving R around the y -axis?

- (A) $\frac{8\pi}{3}$
- (B) 2π
- (C) $\frac{2\sqrt{2}\pi}{3}$
- (D) π
- (E) $\frac{4\sqrt{2}\pi}{3}$

8. A solid has a semicircular base of radius 3. Cross sections perpendicular to the base and parallel to the straight edge of the semicircle are squares. What is the volume of the solid?

- (A) $\frac{9\pi}{2}$
- (B) 72
- (C) 18
- (D) 27π
- (E) $\frac{9\pi}{4}$

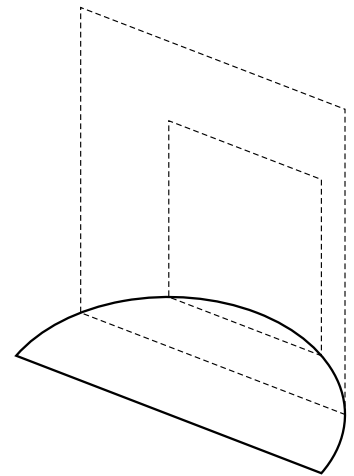

9. Find the surface area of the surface generated when the curve

$$y = \frac{x^3}{3}, \quad 0 \leq x \leq 1$$

is rotated about the x -axis.

- (A) $\frac{\pi(2\sqrt{2} - 1)}{27}$
- (B) $\frac{\pi(2\sqrt{2} - 1)}{9}$
- (C) $\frac{\pi(2\sqrt{2} - 1)}{3}$
- (D) $\frac{\pi(2\sqrt{2} - 1)}{287}$
- (E) $\frac{\pi(2\sqrt{2} - 1)}{81}$

10. Which one of the following integrals equals the arc length of the curve

$$y = x^3 + 1, \quad 1 \leq x \leq 2 \quad ?$$

- (A) $\int_1^2 x^3 + 1 \, dx$
- (B) $\int_1^2 \sqrt{9x^4 + 1} \, dx$
- (C) $\int_1^2 3x^2 \, dx$
- (D) $\int_1^2 \sqrt{x^3 + 2} \, dx$
- (E) $\int_1^2 \sqrt{x^3 + 1} \, dx$

11. Which one of the following integrals equals the volume of the solid obtained by rotating the region bounded by $y = x^2$ and $y = x$ about the line $x = 3$?

(A) $\int_0^1 2\pi(3-x)(1-x^2)dx$

(B) $\int_0^1 2\pi(3-x)^2(x-x^2)^2dx$

(C) $\int_0^1 2\pi(3-x)(x-x^2)^2dx$

(D) $\int_0^1 2\pi(3-x)(x-x^2)dx$

(E) $\int_0^1 2\pi(3-x^2)(x-x^2)dx$

12. A thin metal bar of length 2 m pivots around a hinge on the floor. At x meters away from the hinge, the bar has density $\rho(x) = 10 + x$ kg/m. Assume gravitational acceleration $g = 10$ m/s². How much work *against gravity* is required to pivot the bar upright from a horizontal position?

- (A) 22 joules
(B) 220 joules
(C) 440 joules
(D) $\frac{520}{3}$ joules
(E) $\frac{680}{3}$ joules

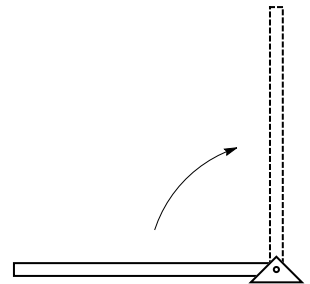

DO NOT DETACH THIS PAGE FROM THE EXAM BOOKLET.
This page is left blank intentionally for scratch work.