

1. Dimos Disability Insurance Company uses the Standard Sickness-Death Model with $i = 0.05$ to price and reserve its disability income policies.

Dimos sells a 10 year disability income policy.

The policy pays premiums continuously when the insured is Healthy during the 10 year period. Premiums are determined using the equivalence principle.

The policy pays a continuous disability annuity benefit at a rate of 60,000 per year while the insured is in Sick. However, all disability annuity benefits will end 10 years from the issue date of the policy.

Noah, age 50 and healthy, buys a 10 year disability income policy.

- a. (6 points) The Actuarial Present Value of Noah's benefits under the policy is 11,800 to the nearest 100. Calculate the Actuarial Present Value to the nearest 1.

- b. (5 points) Calculate the net premium rate payable continuously for Noah's policy.

Dimos also sells a disability income policy which lasts for the lifetime of the insured. The policy pays premiums continuously when the insured is Healthy during the insureds lifetime.

- c. (10 points) Write the Kolmogorov forward equations for all the probabilities for a life age x , who currently is Sick. Give boundary conditions.

The lifetime policy pays a lump sum death benefit at the moment of death of 50,000 and also pays a continuous disability annuity benefit at a rate of 30,000 per year while the insured is in Sick.

Hannah who is age 55 purchases a disability income policy which lasts for the lifetime of the insured. **Hannah's net premium rate payable continuously based on the equivalence principle is 8778.**

- d. (8 points) Calculate the reserve for this at the end of 10 years assuming that Hannah is Healthy at the end of 10 years.

- e. (8 points) Calculate the reserve for this policy at the end of 10 years assuming that Hannah is Sick at the end of 10 years.

- f. (8 points) While these two policies issued by Dimos do not have a waiting period before disability income benefits begin, most policies do. Please list reasons why a waiting period is advisable.

2. Jake, who is now 75 years old, is entering a Continuing Care Retirement Community (CCRC) under a Full Lifecare (Type A) contract. He will move into an Independent Living Unit (ILU). Jake pays a one-time fee of F immediately on entry and a level monthly fee of M at the start of each month that he is in the CCRC, including the first.

You are given:

- (i) The entry fee, F , is equal to 30% of the expected present value of all future costs.
- (ii) The CCRC operates three types of accommodation; they are listed here, with the monthly costs incurred at the beginning of the month by the CCRC for each resident in each category:

Independent Living Unit (ILU):	5,000
Assisted Living Unit (ALU):	9,000
Specialized Nursing Facility (SNF):	13,000

- (iii) $i = 0.05$
- (iv) The monthly fee M is determined so that the expected present value of the monthly costs is equal to the expected present value of M plus the expected present value of F .
- (v) The CCRC uses the following multiple state model to determine the fee structure.

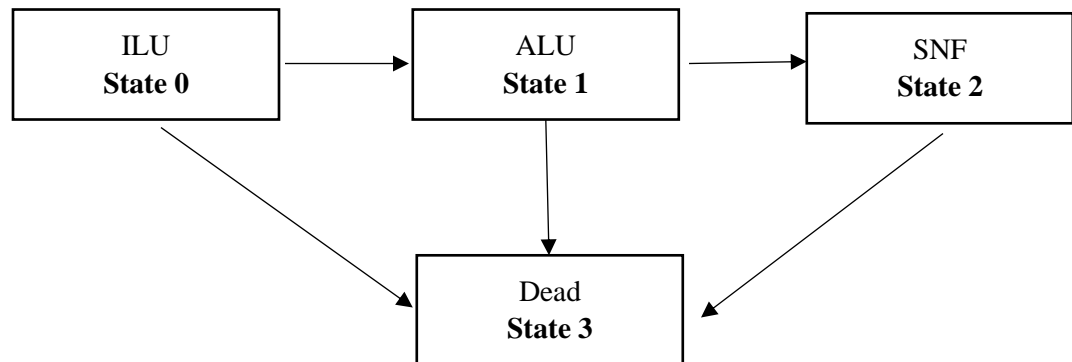

- (vi) The following actuarial functions have been evaluated for the model at $i = 0.05$

x	$\ddot{a}_x^{(12)00}$	$\ddot{a}_x^{(12)01}$	$\ddot{a}_x^{(12)02}$	$\ddot{a}_x^{(12)11}$	$\ddot{a}_x^{(12)12}$	$\ddot{a}_x^{(12)22}$	$A_x^{(12)03}$
70	9.5210	1.7037	0.4942	10.1754	0.9960	9.1961	0.4294
75	7.4080	2.1230	0.5122	8.2234	1.2121	7.4238	0.5231

a. (6 Points) You are given that F is 226,000 to the nearest 1000. Calculate F to the nearest 1.

b. (6 points) Calculate M .

3. (8 points) For a fully continuous whole life of 100,000 on (50), you are given:
- a. The gross premium reserve at $t = 20$ is 28,000.
 - b. The gross premium is paid at a rate of 2000 per year.
 - c. The force of interest is 6% .
 - d. The force of mortality follows Gompertz law with $B = 0.0015$ and $c = 1.03$
 - e. The following expenses payable continuously:
 - i. 70% of premium in the first year and 8% of premium in years 2 and later;
 - ii. 50 per policy in the first year and 20 per policy in years 2 and later; and
 - iii. 1000 payable at the moment of death.

Estimate the gross premium reserve at $t = 20.25$ using Euler's method with $h = 0.25$.

4. (12 points) The Li Life Insurance Company uses a double decrement table to price life insurance policies. The double decrement table will be based on two single decrement tables. Under the single decrement tables, you are given:

For age 50, Li assumes that decrements are distributed uniformly in the multiple decrement table.

For Age 51, Li assumes that decrement (1) is distributed uniformly in the single decrement table and that all decrements from decrement (2) occurs at time 0.75.

Complete the following table with each probability accurate to 5 decimal places. Show your work.

x	$q_x^{(1)}$	$q_x^{(2)}$	$q_x^{(1)}$	$q_x^{(2)}$
50			0.25	0.10
51	0.20	0.13		

5. Adam's Accidental Assurance Company (AAA) issues two year term policies which provide:
- i. A death benefit of 100,000 at the end of the year of death from natural causes which is decrement 1;
 - ii. A death benefit of 400,000 at the end of the year of death if death occurs from an accident on public transportation (plane, taxi, uber, lyft, train, subway, etc) which is decrement 2; and
 - iii. A death benefit of 200,000 at the end of the year of death if death occurs from an accident other than on public transportation which is decrement 3.

These policies have net annual premiums determined using the equivalence principle.

You are given that $v = 0.10$ and the following triple decrement table:

x	$q_x^{(1)}$	$q_x^{(2)}$	$q_x^{(3)}$
20	0.050	0.010	0.025
21	0.060	0.005	0.020

David who is age 20 buys a policy from AAA.

- a. (7 points) Lauren who is the Chief Actuary at AAA calculates David's premium. The premium that Lauren calculates is 11,790 to the nearest 10. Determine the premium to the nearest 1.

- b. (6 points) T. Fuego who works for Lauren calculates the reserve at the end of one year. Determine the reserve that T. Fuego calculated. **Note that the reserve is negative.**